

# Dome Deck Methods

Erecting the dome on a pre-existing deck can be problematic. Please contact us if you plan to do so. Also contact us if your dome has a pre-hung door placement that may require modifications to the deck outline.

Our shelter domes are designed with a hem that connects to the side of a raised deck, below the floor level. We suggest the following options for building decks to interface with our shelter dome hem:

## 1. Portable “Pie Piece” or “Star” Method

The portable “Pie Piece” (16’, 20’, and 24’) and “Star” (30’ and 36’) methods allow the deck to be disassembled in sections and moved easily. You can take it apart, load it up and move it all in a day’s work. It costs a little more than the joist method and is more complex to build.

## 2. Stationary Joist Method

This method requires less time and materials to build than the portable methods. We recommend a joist deck for people that don’t expect to move their dome. You can make this method semi-portable by using screws instead of nails.

## 3. Perimeter Boards

We recommend this method for domes with earthen floors. The perimeter board will anchor your dome and keep the fabric off the ground. You can also use the perimeter board as a mould to lay tiles or pour concrete. Concrete floors can be painted beautifully. Coat the concrete with marine varnish for easy cleaning. If perimeter boards are used as forms for concrete, we recommend using pressure-treated, rot-resistant wood, and leaving the boards in place to receive the shelter hem. 16-penny, galvanized nails started into the inside of the perimeter boards will secure the boards to the slab.

## 20 ft. Dome Floor - "Pie Piece" Method

1. From 10 of the 10 ft. boards cut 10 "1A" boards.  
From 20 of the 10 ft. boards cut 20 "2A" boards.  
From 15 of the 10 ft. boards cut 15 "B", "C", "D" and "E" boards.  
From 15 of the 10 ft. boards cut 15 "F" and "G" boards.

*NOTES:* All boards are measured on longest side.

2. Assemble the 15 pie piece frames as per drawing.
3. Level one pie piece frame on high side of land with center of pie pointing downhill. Place 1' x 1' x 3/4" pine or plywood on top of center post to support 15 pie pieces. Outer piers and posts may be about half a foot from the B boards and will support two adjacent pieces.  
*NOTE:* The door goes on a point.
4. Set the second pie piece frame on the center post and one post of the first pie piece frame. Level the second piece and set the fourth pier and post for the other side.
5. Measure your decking material and calculate where three bolts should be located for easy access upon removal of specific decking boards.
6. Drill three 5/16" holes through the adjacent A and bolt them together.  
*NOTE:* A "C" clamp may be useful here.
7. Repeat the procedure adding one more pier and post and bolting one more frame until all the piers are set, the posts are cut and the frames are bolted.  
*NOTES:* The last frame may need to be pounded into place and other bolts may need to be loosened for placement of the last frame.
8. Cover with suitable decking.

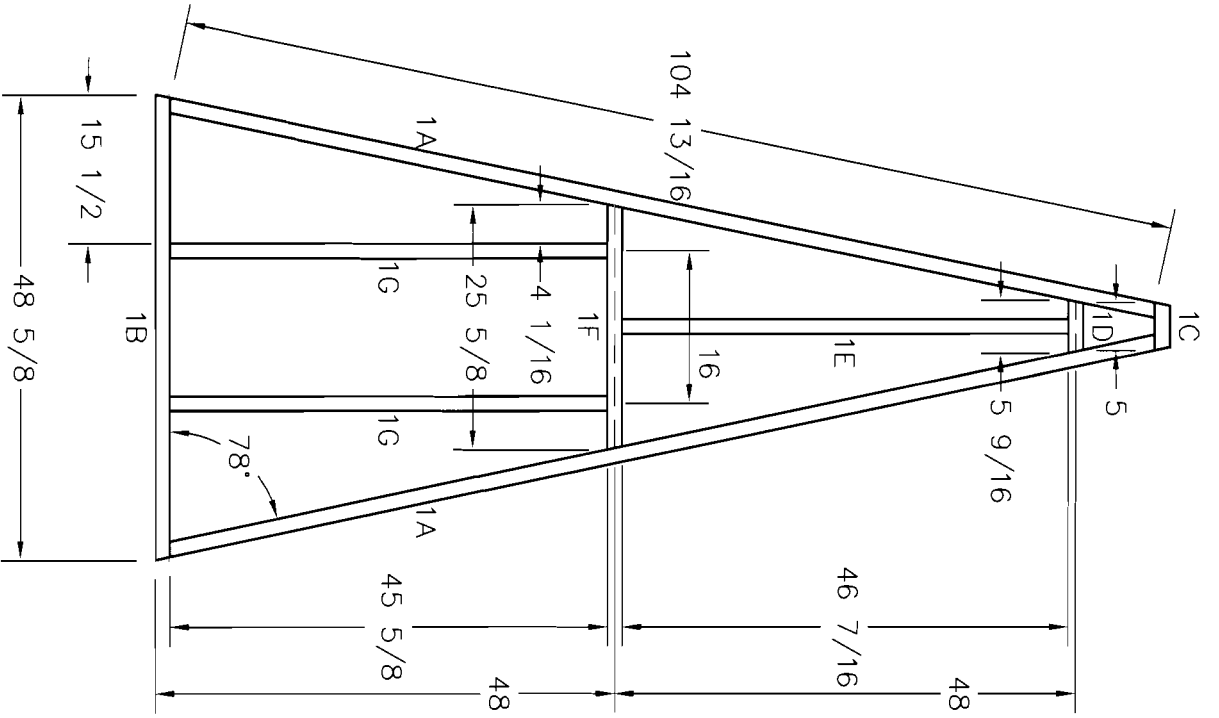

MAKE FIVE #1

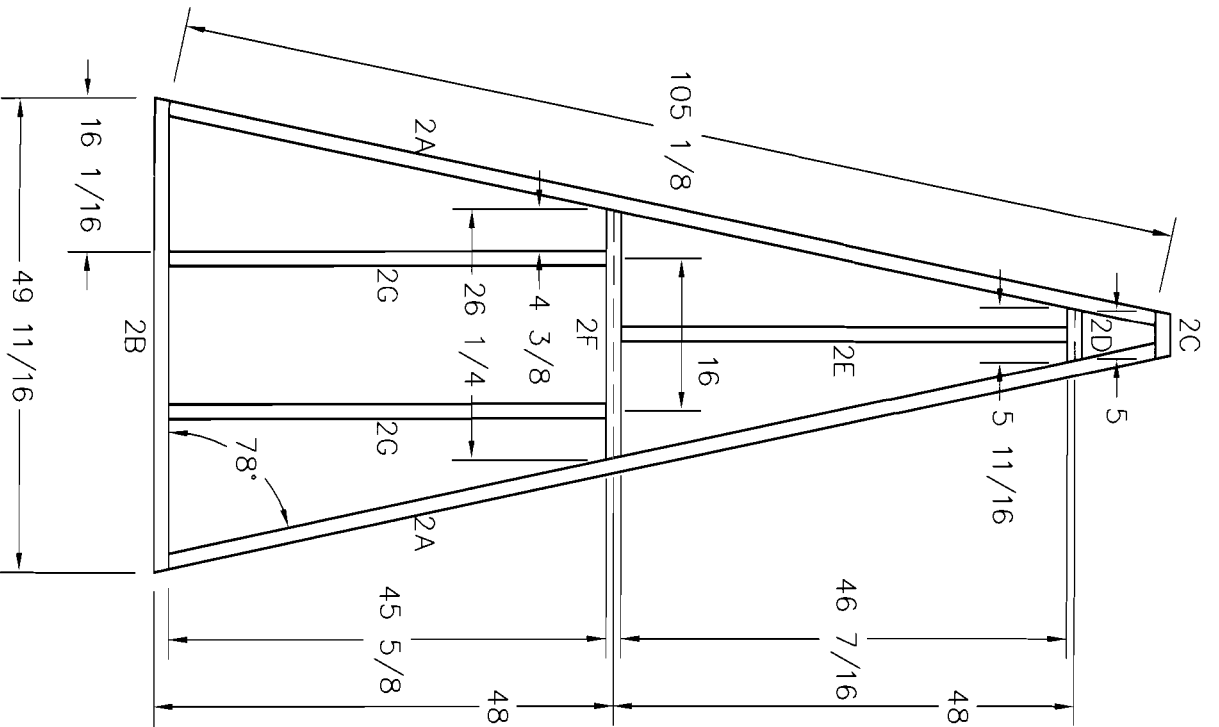

MAKE TEN #2

PACIFIC DOMES

DRAWING NAME:  
20' PIE DECK

DRAWING NUMBER:  
SD-20-015

DATE:  
5 JAN 2006

DRAWN BY: PAGE:  
TES 1 OF 1

REV:  
A

## 20 ft. Dome Floor – “Pie Piece” Method

### Materials

16	Wood-topped pier blocks
1	4 x 4 post to level
60	2" x 6" x 10 ft.
45	5/16" x 3-1/2" hex bolts
45	5/16" hex nuts
90	5/16" washers
10#	16d galvanized box nails
10	3/4" Plywood
20#	Deck nails or screws
2 gal.	Marine varnish

Cut List	Amounts	Length
1A:	10	104 <sup>13/16"</sup>
1B:	5	48 <sup>5/8"</sup>
1C:	5	5"
1D:	5	5 <sup>9/16"</sup>
1E:	5	46 <sup>7/16"</sup>
1F:	5	25 <sup>5/8"</sup>
1G:	10	45 <sup>5/8"</sup>

\*All angles 12°

Cut List	Amounts	Length
2A:	20	105 <sup>1/8"</sup>
2B:	10	49 <sup>11/16"</sup>
2C:	10	5"
2D:	10	5 <sup>11/16"</sup>
2E:	10	46 <sup>7/16"</sup>
2F:	10	26 <sup>1/4"</sup>
2G:	20	45 <sup>5/8"</sup>

## 20 ft. Dome Floor – Joist Method

1. Lay out the pier blocks according to *Figure 1*. Dig each pier block into the ground an inch or two and make each level with itself.
2. Cut and lay out beams according to *Figure 1*. Leave the ends of the beams long (extending past the perimeter of the floor). Cut them later.
3. Level the beams with lengths of 4"x4" atop the piers.
4. From 8 of the 10ft. boards, cut 15 "C" boards.  
From 10 of the 20ft. boards, cut 1 ea. "D", "E", "F", "G", "H", "K", "L", "M", "N" and "O" boards.  
From 4 of the 16ft. boards, cut 1 ea. "I", "J", "P", "Q" and "R" boards.

*Note:* All board length dimensions refer to the long side of the board.

5. Frame according to fig. 2. All joists are 16" centers.
6. Cover with plywood according to fig. 3.

## 20 ft. Dome Floor – Joist Method

Material List	
Qty.	Item
16	Wood-topped pier blocks
A/R*	4" x 4"
2	4" x 6" x 20ft.
2	4" x 6" x 12ft.
10	2" x 6" x 20ft.
4	2" x 6" x 16ft.
8	2" x 6" x 10ft.
10#	16d galvanized box nails
10#	8d galvanized nails
15	3/4" plywood
2 Gal.	Exterior varnish
*As Required	

Frame Cut List				
Letter	Qty.	Size	Length <sup>1</sup>	Ends
A	2	4" x 6"	20ft.	0
B	2	4" x 6"	12ft.	0
C	15	2" x 6"	49 <sup>3/8</sup> ,"	12°
D	1	2" x 6"	233"	18°
E	1	2" x 6"	222 <sup>5/8</sup> ,"	18°
F	1	2" x 6"	212 <sup>3/16</sup> ,"	18°
G	1	2" x 6"	199 <sup>7/8</sup> ,"	42°
H	1	2" x 6"	171 <sup>1/16</sup> ,"	42°
I	1	2" x 6"	142 <sup>1/4</sup> ,"	42°
J	1	2" x 6"	77 <sup>3/16</sup> ,"	66°
K	1	2" x 6"	229 <sup>15/16</sup> ,"	6°
L	1	2" x 6"	226 <sup>5/8</sup> ,"	6°
M	1	2" x 6"	223 <sup>1/4</sup> "	6°
N	1	2" x 6"	206 <sup>11/16</sup> ,"	30°
O	1	2" x 6"	188 <sup>3/16</sup> ,"	30°
P	1	2" x 6"	163 <sup>5/8</sup> ,"	54°
Q	1	2" x 6"	119 <sup>9/16</sup> ,"	54°
R	1	2" x 6"	27 <sup>3/4</sup> "	78°

All lengths are shown for the long side of the board.

PIERS AND BEAMS  
 JOIST PERIMETER SHOWN IN PHANTOM

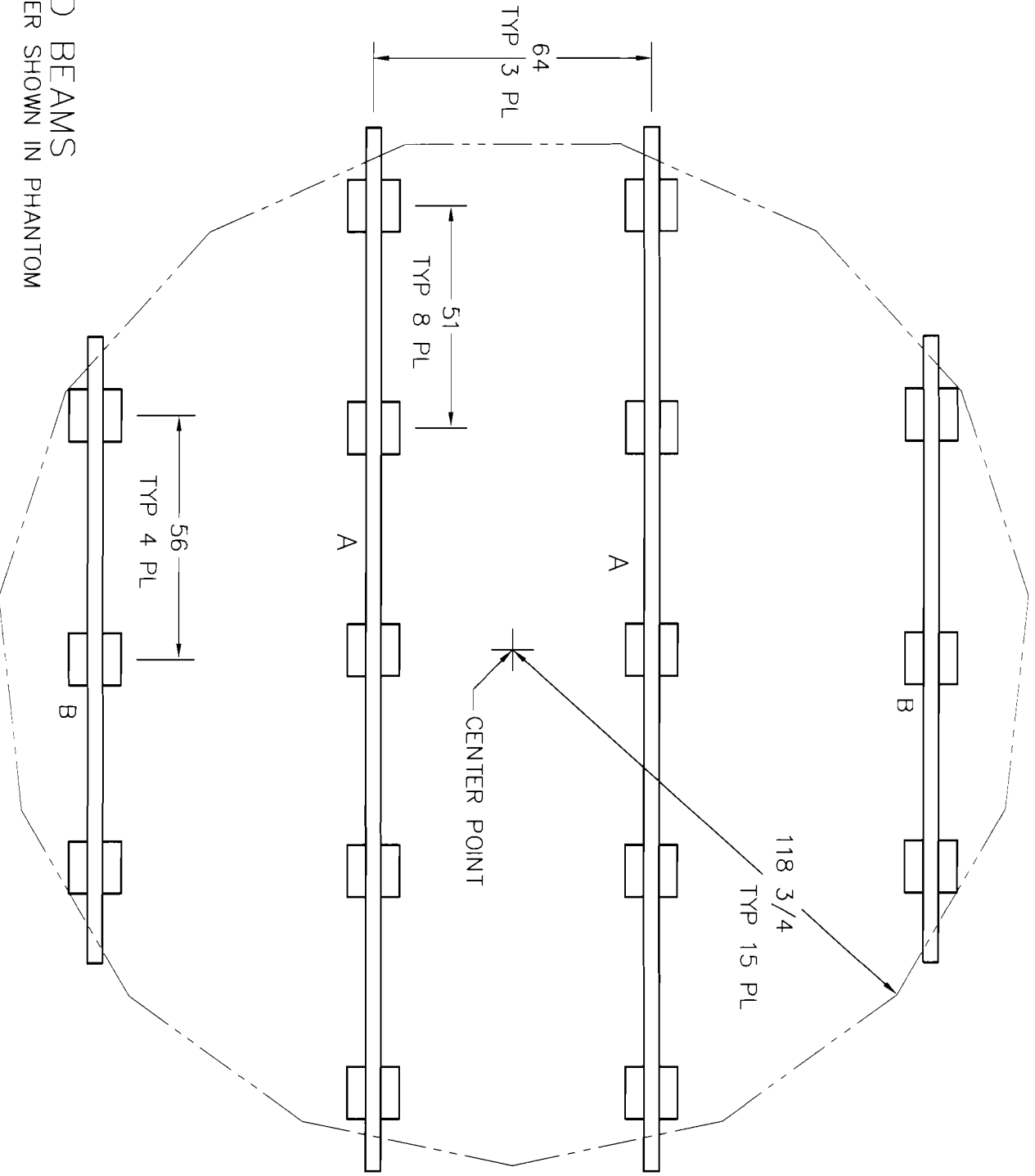

PACIFIC DOMES

DRAWING NAME:  
 20' JOIST DECK

DRAWING NUMBER:  
 SD-20-016

DATE:  
 13 JAN 2006

DRAWN BY: TES  
 PAGE: 1 OF 3  
 REV: A

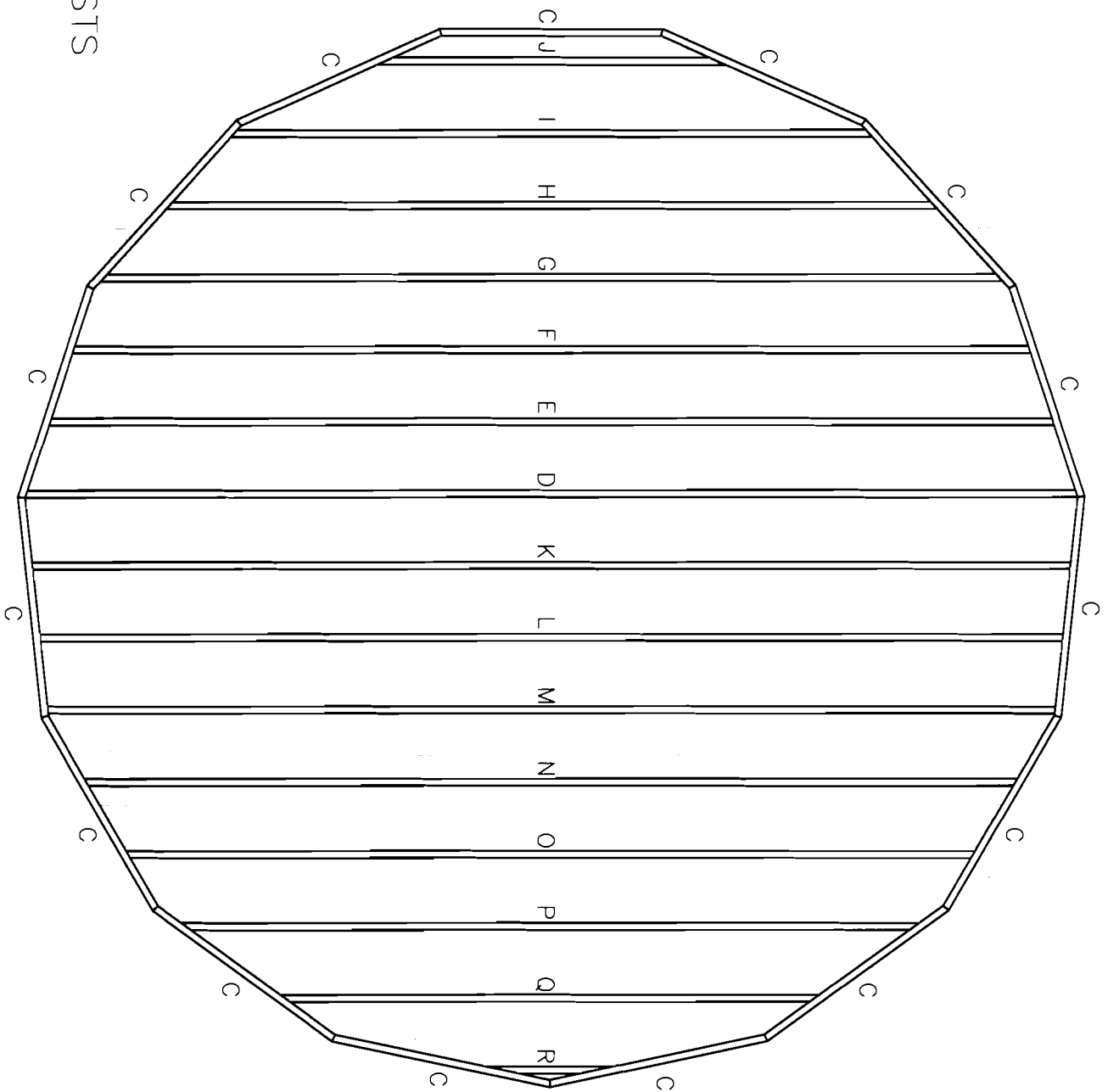

PACIFIC DOMES

DRAWING NAME:  
20' JOIST DECK

DRAWING NUMBER:  
SD-20-016

DATE:  
13 JAN 2006

DRAWN BY:  
TES

PAGE:  
2 OF 3

REV:  
A



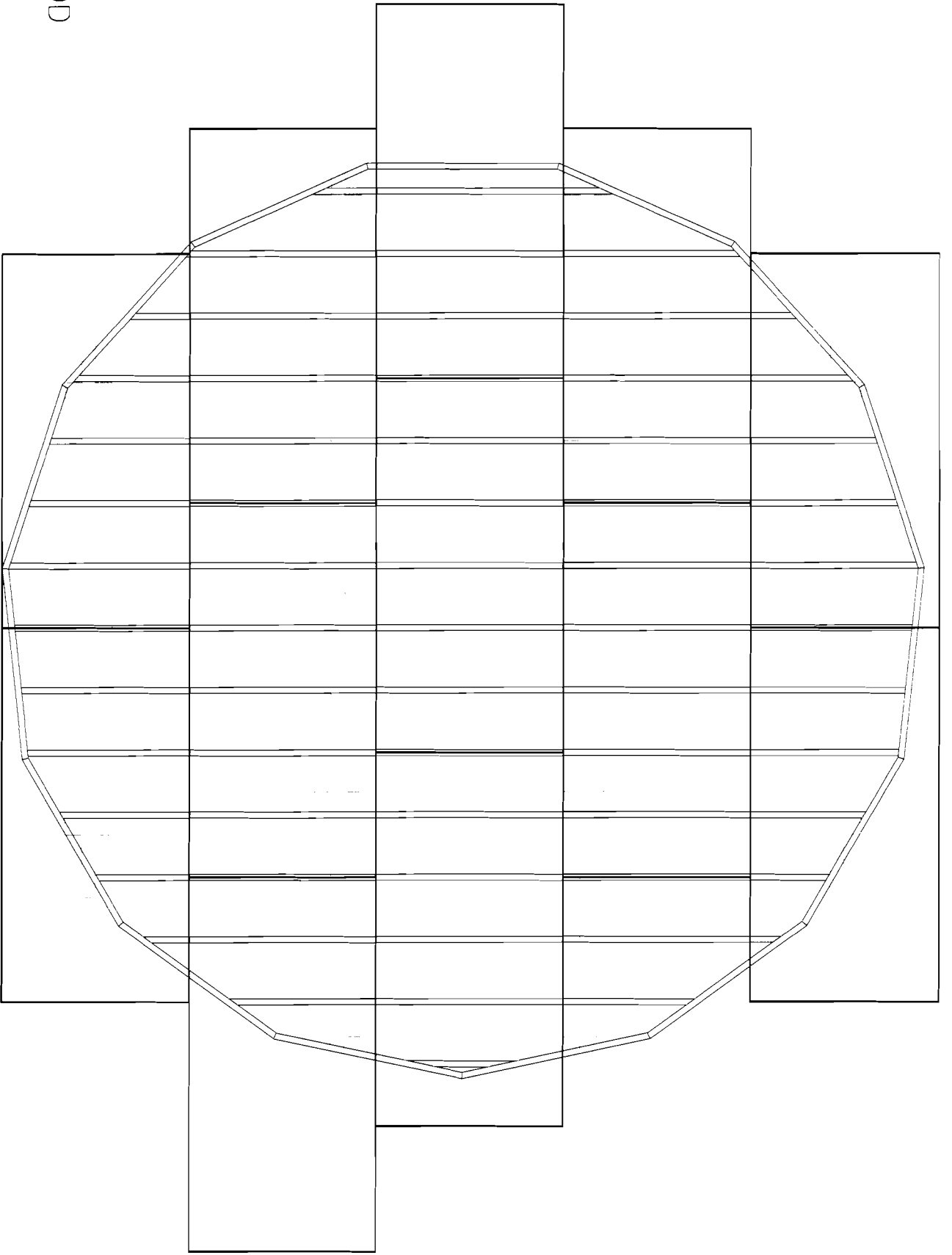

PLYWOOD

PACIFIC DOMES

DRAWING NAME:  
20' JOIST DECK

DRAWING NUMBER:  
SD-20-016

DATE:  
11 JAN 2006

DRAWN BY: PAGE:  
TES 3 OF 3

REV:  
A

## 20 ft. Dome – Perimeter Boards for Setup on Earthen Floor

1. Cut 15 pieces of lumber, 49-7/16" long on the long side, with 12° angles on each end (see *diagram*). You may use 2x6, 2x8, 2x10, 2x12, 4x4, etc., cedar, redwood, or fir. In the diagram the dashed line represents the width of 4" lumber. Shorter boards leave the dome skin close to the ground and, in moist situations, this may cause premature failure of the skin. Taller boards will make the dome taller and will be harder to step over when you enter the dome. Cedar, redwood or pressure treated fir is required to ensure resistance to rot in cases where the wood is in contact with the earth or moisture for extended periods of time.
2. Pre-drill pilot holes and screw adjacent perimeter boards together, from the outside, with galvanized or zinc chromate-plated drywall screws, 3" or longer. For assembly on pre-existing floor, seal between the boards with a quality caulk/sealant. We do not encourage setting up on a pre-existing floor because if it is not done properly, moisture will get in.
3. Measure and adjust the diameter in several places to resemble those shown in the diagram.
4. Make the perimeter boards coplanar with a visual check and the back of a hammer or other digging tool. Coplanar means "on the same plane." This is not necessarily level. Place your dome frame on the top of the perimeter board, placing the hubs on the outer edge of perimeter board points.
5. To anchor your dome against high winds, drill a hole through each perimeter board and pound rebar through the hole and into the ground.
6. Assemble the dome struts and cover with the skin. Fasten the skin to the perimeter boards through the grommets with the provided screws.

20' DOME PERIMETER BOARDS  
FOR EARTHEN OR  
PRE-EXISTING FLOORS

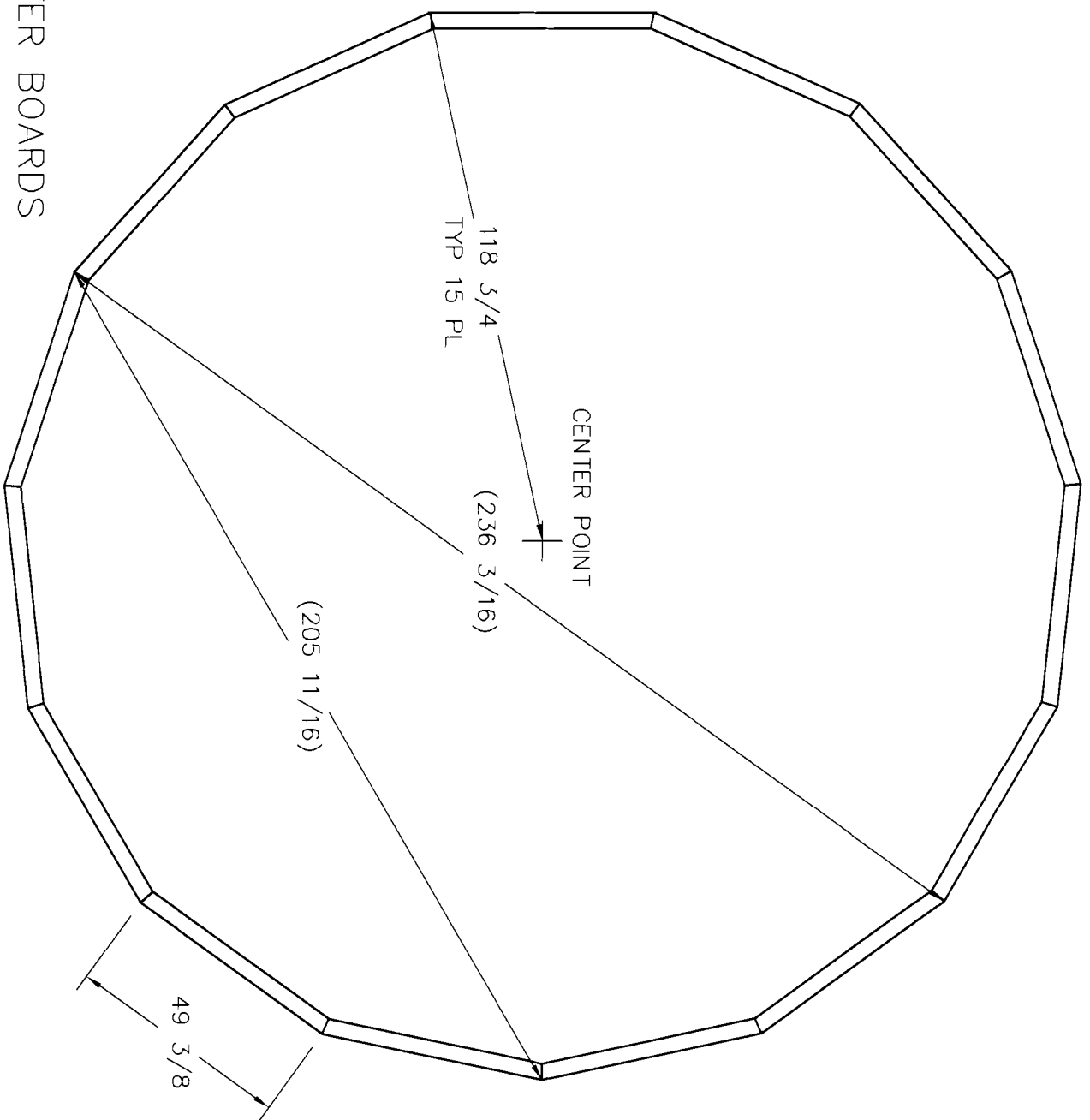

PACIFIC DOMES

DRAWING NAME:  
20' PERIMETER

DRAWING NUMBER:  
SD-20-17

DATE:  
13 JAN 2006

DRAWN BY: PAGE:  
TES 1 OF 1

REV:  
A

# Cob Floors For Domes

\*Use in conjunction with our wooden perimeter plans

## **General Info.**

Cob is a natural building material made from clay, sand, straw and water. Cob is an inexpensive alternative to wood or cement. Cob floors have an earthy and organic feel and can often be made from materials already available.

## **Siting and designing a cob floor:**

Choose a site for a cob floor at the top of a small rise or ridge where water will flow away from your dome. If your ground is sloped, you might consider having a multi-leveled floor. A multi-leveled floor can help define different areas, by stepping or gently sloping the cob-floor cold air can be directed, like water, to the lowest point. In some climates it is possible to use this method for cold storage, even instead of a refrigerator. Yet you should plan for your finished floor to be at least two inches above the ground.

## **Temperature:**

The temperature in the ground below the frost line is the same as the average yearly air temperature. This temperature is constant throughout the year. If this is a comfortable temperature, you can build your cob floor directly on the ground, and your floor will stay approximately the same temperature as the average air temperature. If the ground temperature is really cold, you may need to insulate underneath and around the edge of the floor. This will reduce the time it takes for heat from the sun or wood stove to reflect back into your space. You can get information from your local builders and building department about the optimum thickness of your cob floor and how deep the insulation should be. (Pretend its concrete as they probably wont understand cob yet.)

## **Passive solar:**

By facing your bay window to the south/southeast, you can optimize your floor's ability to gather heat from the sun in the winter. Cob floors have plenty of thermal mass and can effectively store this energy. Cob can also be used to make benches and wood stoves, which will increase thermal mass generated by your living space.

## **Radiant floor heating systems:**

Running hot water through pipes that are buried in the floor makes radiant floor heating systems. The water can be heated with a modified wood stove or a conventional water heat. This system is compatible with earthen and wood floors. If you choose this method, plan for the cob to be thick enough to cover the hot water pipes. You can find detailed information about radiant floor heating on the Internet.

## **Building a Cob Floor:**

### **Step 1: Site preparation**

First remove the topsoil from your site. Put it where your garden will be! Then level and tamp the sub soil. A base is necessary under the cob unless the soil on site is stable, the area is very dry, and the water runoff from the dome can drain well. In any case you will want a good drainage system to keep your floor from being flooded. A few inches of hard gravel makes a good base, but the more gravel you can put under your perimeter the better. Using hard rock is important, as water will wick through soft rock. Sand or silty soil with a bit of clay also makes a good base, roughly level it. If you use a gravel base either sprinkle it with straw or place old sheets over the gravel. This is necessary to keep the dirt and cob from seeping down into the gravel.

### **Step 2: The cob mix**

The standard cob floor mix is made from 75-85% sand, and 15-25% clay, finely grated straw, and water. An alternative to straw is 15-25% horse or cow manure sifted through a 1/2 inch mesh, and water. Mix the ingredients together well, using your feet. Then put the mixture in a tarp and roll it like dough. The mixture should be stiff like dry brownie dough. You can also add school or carpenter's glue, ground psyllium seed husk, manure, blood, wood ash, oil, or flour to harden, add bounce, or color.

### **Step 3: Applying the cob**

Trowel the mix onto the base in big swaths 1/2" to 1 1/2" thick. You can do one or multiple layers with a final 1/2" finish layer. Start Applying the cob on the far side of the dome and work your way toward the door. The floor will need to dry for up to three weeks before it can be sealed. Drying time depends on the size, thickness, and wetness of the floor, air moisture and movement. Open up the windows and door to speed drying. It can take a month to dry in the winter.

This is a summary of cob floor building. It is not intended to be complete instructions. Please refer to [The Cob Builders Handbook](#) for more detailed instructions.

[The Cob Builder's Handbook](#) by Becky Bee is available from Groundworks, PO Box 381, Murphy, OR, 97533. They can also be contacted by email at [cobalot@hotmail.com](mailto:cobalot@hotmail.com), and their website is [www.cpros.com/~sequoia](http://www.cpros.com/~sequoia).

### **Other Earthen Floor Possibilities:**

Flat stones, brick, heavy clay, rammed earth, soil cement, and tiles can all be used to make an earthen floor. Depending on your artistic preference and the landscape you are building on, you can combine different earthen floors. A one piece cob floor is the most durable type of earthen floor.